

EXC-BS400ABL LED Flood Light

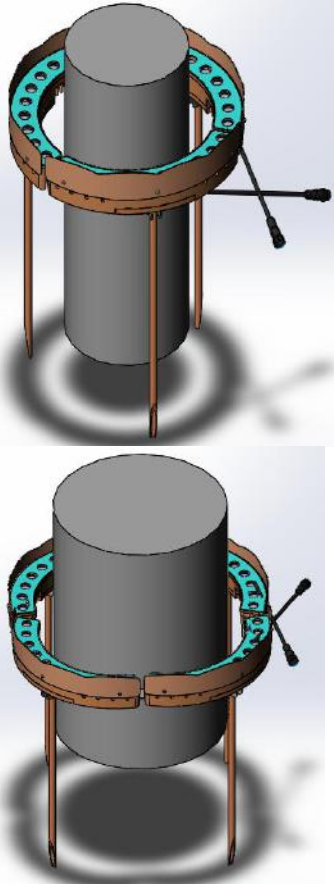

Application Environment:
Indoor
Outdoor

Description:

EXC-BS400ABL Light tree lamp are high power outdoor landscape flood lighting fixture with high strength aluminum alloy housing by EXC-LED. Each lighting fixture can be used for accent lighting or flood lighting, such as, landscape garden, etc.

Features:

- The newest generation technology: DMX512 parallel bus design
- A new generation of structural waterproof design
- High strength aluminum and low thermal resistance path cooling design
- High reliability modularization design
- Outdoor lighting protection and electrostatic discharge (ESD) protection design
- Load safety design

Basic Specifications

Color Range	W(2200K-6500K), RGBW
Working Voltage	DC 24V
Max. Power Consumption	24W/30W/36W(White), 15W/20W/24W(RGBW)
Light Source	8/10/12 PCS High Power LEDs
LED chip Brand	Optional(Cree, OSRAM, Lumileds, Epistar, etc...)
CRI	80
Control	DMX512, ON/OFF
Source Life	50,000 h
Housing	High Strength Aluminum
Cover	Tempered glass

Weight	1.7Kg(Single module lamp)
Dimensions	395mm x 58mm x 53mm (L x W x H, exclude Mounting Bracket)
Installation	Installation with screws or adhesive
Working Temperature	-40°C to 60°C
Storage Temperature	-40°C to 70°C
Protection Rating	IP66
Luminous Flux	50LM/W(White), 20LM/W(RGB)
Beam Angle	W-3030P7: 10°/15°/20°/30°/45°/60°/80° RGB-3030P7/CREE XP series: 6°/8°/10°/15°/20°/30°/45°/60°/80° 3535:30°/45°/60°/80° 5050: 17°/20°/30°/45°/60°

Host Controller	EXC-5200
Slave Controller	EXC-2905T1
Signal Cable	EXC-LED outdoor special cable

Light Intensity Distribution

Light Intensity Chart

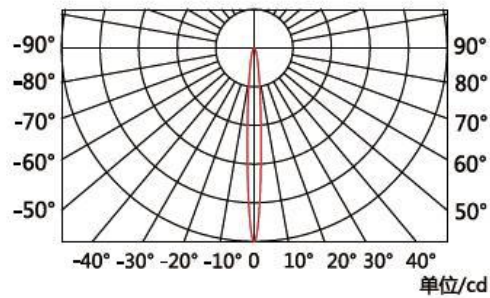

— C0/180 10°
— C90/270 10°

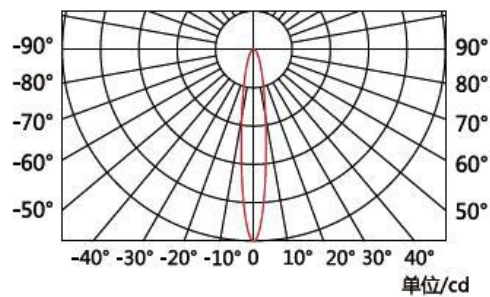

— C0/180 15°
— C90/270 15°

Physical Dimension

Unit: mm

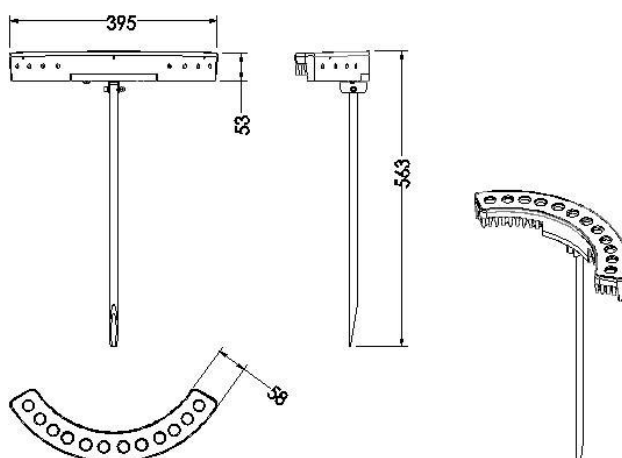
**Installation Diagram**

1. Use 2 combination M5 screw and fix the high bracket assembly at the bottom of the lamp

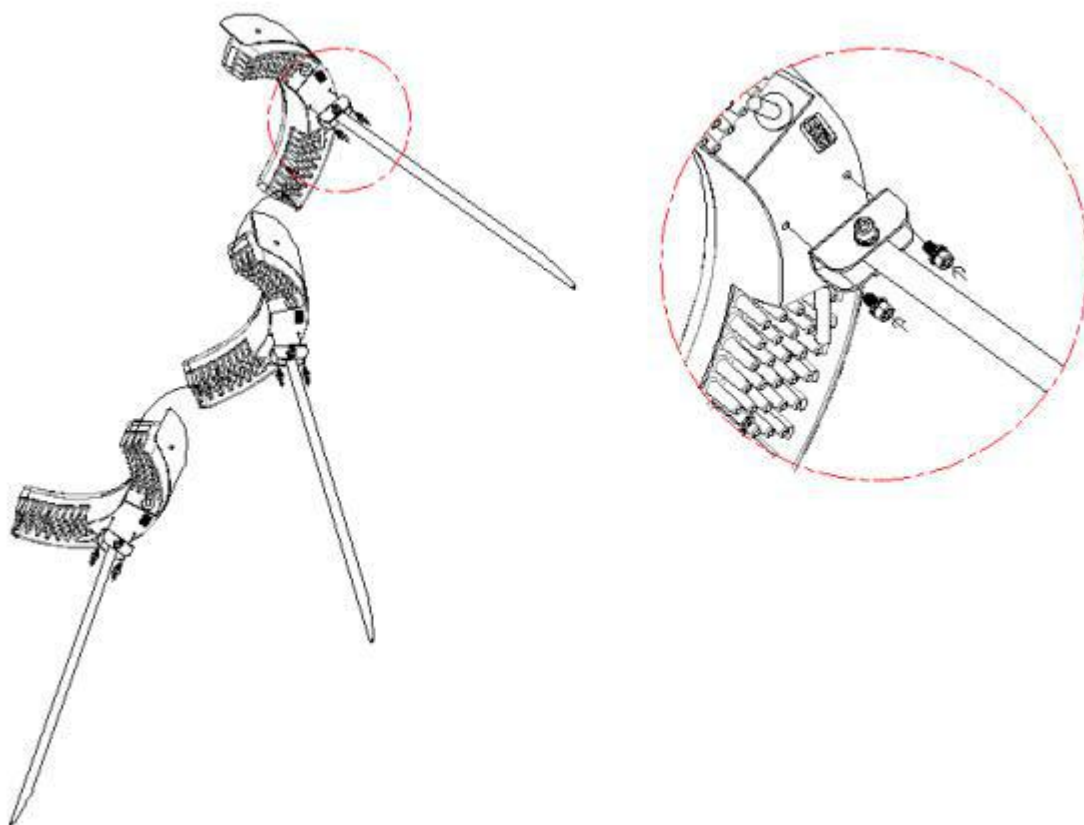

2. As shown in the figure, surround the tree with lamps and connect each lamp with M5 combination screw

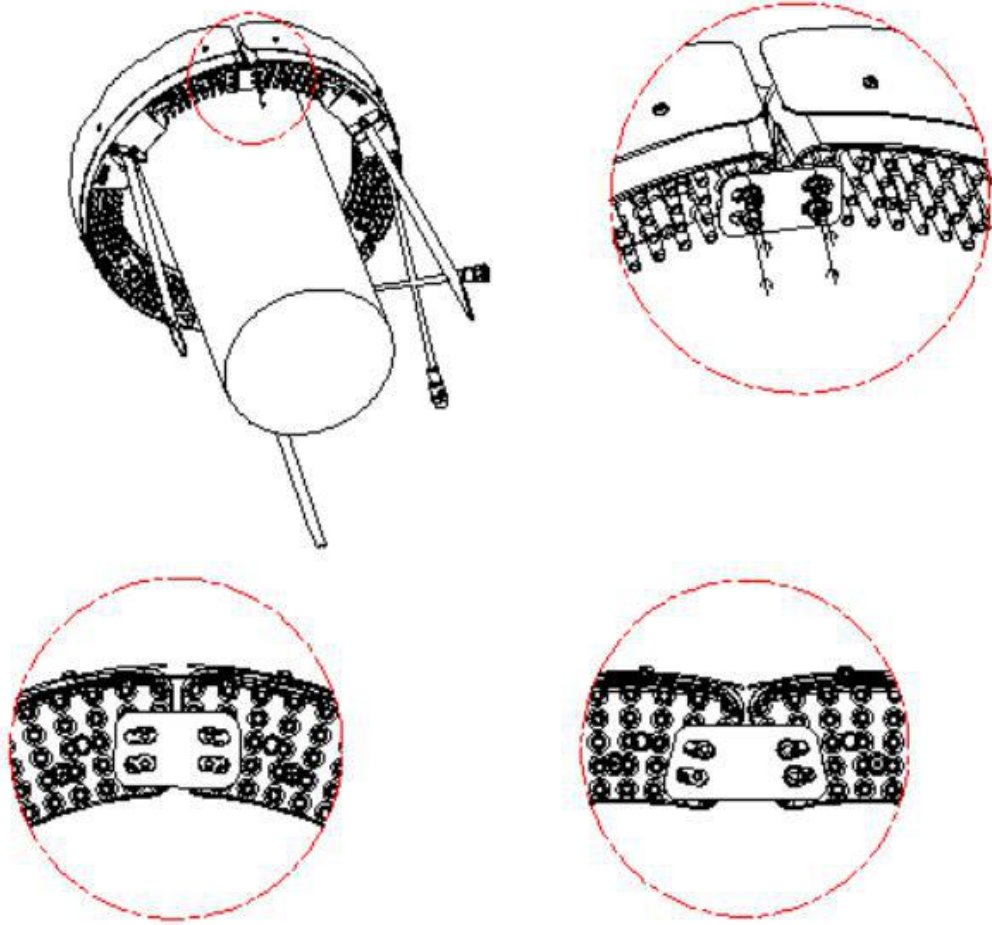

3. As shown in the figure, insert the lamp brackets into the ground

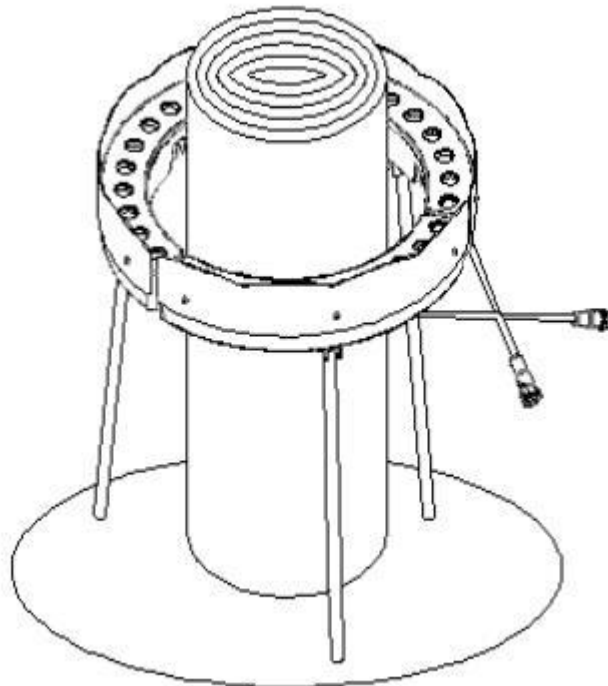

System connection diagram:

- 1、 Host controller should connect with slave controller. Working voltage for controllers are AC220V.
- 2、 On-line main controller should connect with slave controller, on-line main controller and sub controller working voltage are AC220V.
- 3、 each sub-controller with 8 ports, with each port 512 pixels, supporting data converter, supports 100 meters ultra-long haul transmission.
- 4、 The CAT-5 e. cable distance should be within 100 meters between host controller and slave controller, between slave controllers and switch, etc.

Accessories :

1: Female and Male Connector(Connect to first dot light for signal transmission)

Female Connector

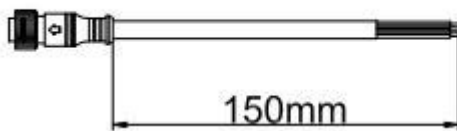

Male Connector

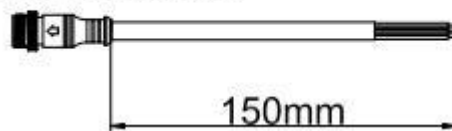

2: Y Shape Connector(For power Distribution)

Male Connector

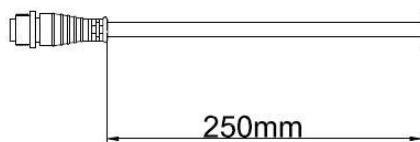

350mm

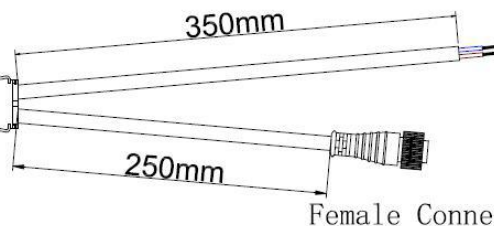

250mm

Female Connector

3: Interconnection Cable(1.3M,3M,5M is standard length)

Female Connector



Male Connector



4: End Cap

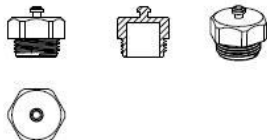

Male Connector

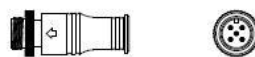

Male Connector

